

Classe 5 USB Compact 2 Group

Entry to mid-range traditional espresso machine

The Classe 5 exemplifies functional minimalism combined with contemporary aesthetics. The intuitive brew group control buttons are designed for instant interaction between the barista and the machine, with 4 programmable brewing settings per group. Body panels are crafted with brushed stainless steel, ABS, and nylon for an attractive design that is built to last. The compact model version makes these features available in a space-saving footprint.



Standard Features

- 4 programmable volumetric controls per group for a simple and consistent workflow
- Highly-efficient heat exchange boiler with Steady Brew technology
- Electrical heating
- Durable and attractive stainless steel, nylon, and ABS body panels
- 2 manual steam wands with ergonomic C-Lever handle
- Powerful volumetric pump
- Boiler pressure control gauges
- USB port makes it easy to save drink parameters and update software or programming
- Hot water outlet with manual button control
- Durable polymer drip tray inserts are easily removable and dishwasher-safe
- Adjustable feet
- 1 year parts warranty

Options

iSteam: Intelligent steam wand that automatically infuses air and turns off at the proper temperature to create the perfect milk for cappuccinos and lattes (pictured)

Color: Available in Anthracite Black or Ice White

Accessories Included

- 2 double portafilters
- Rubber blind disks (for cleaning)
- User manual
- Foot extensions

Space Requirements

- Allow at least 6" of clearance on all sides of the machine
- Allow 24" H x 5" W for in-line water filtration system. Filter system can be mounted behind the machine or under the counter
- Allow at least 3" of clearance under the filter cartridge to facilitate filter change

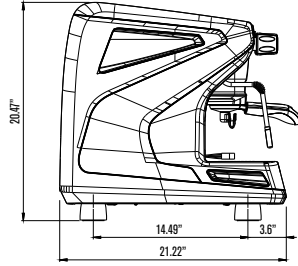
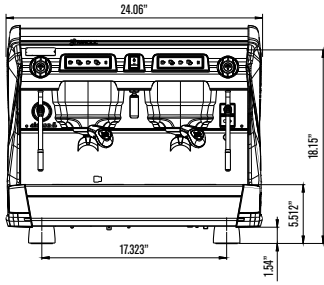

Electrical Connections

Voltage 208-240 VAC
 Element 3000 W
 Circuit Size 20 A
 Receptacle NEMA L6-20R

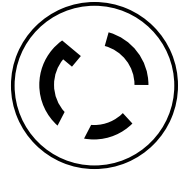

Note: Power can be installed under or above counter. Please allow 3-4" of clearance for the plug, especially when installing power above the counter and behind the machine.

Equipment Dimensions

Machine Dimensions

Width	Depth	Height	Weight
24.06"	21.22"	20.47"	110.2 lbs

Shipping Dimensions

Length	Width	Height	Weight
36"	36"	30"	155 lbs

Countertop Drilling Plan

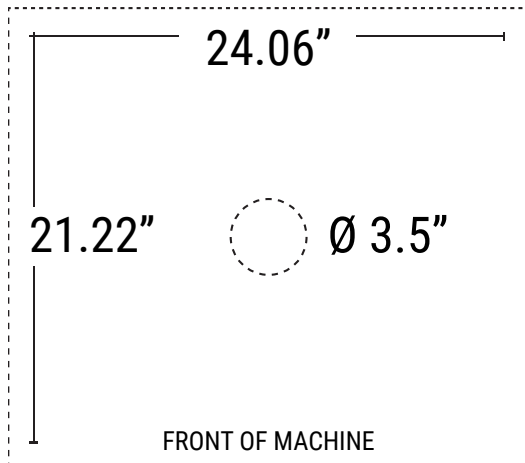

Water Connections

Dedicated cold water access line with standard female 3/8" NPT fitting and manual shut-off valve within 4' of the machine required.

Drain Requirements

Open gravity drain with minimum 2" I.D. within 4' of the machine required.

Water Quality Statement

The fact that water is potable is no guarantee that it is suitable for coffee equipment. Your water supply must be within these general guidelines:

Supply Pressure: 30-70 psi

Hardness: 2-3 GPG (1 grain of hardness = 17.1 ppm)

Water entering the machine should have a water hardness level of 2-3 GPG at all times. If the water supply is not within this range, a dedicated water softener (if above 3 GPG) or mineral addition cartridge (if below 2 GPG) is required for the equipment to operate properly over time. See full Water Quality Statement for further details.

